

BICICHARGER solar

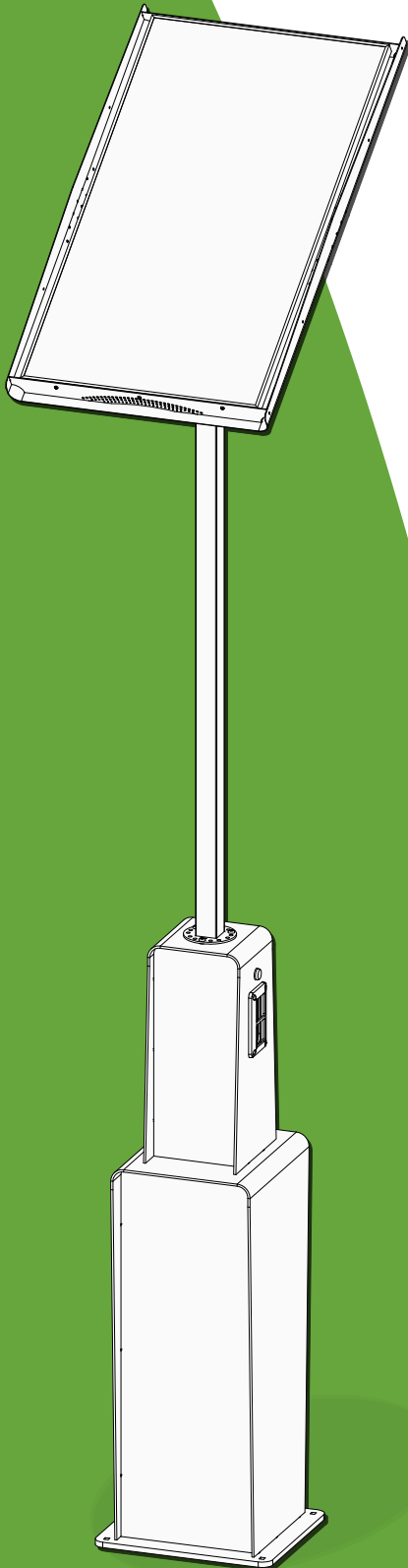

SELF-SUFFICIENT BICYCLE CHARGING STATION

The **BICICHARGER Solar** is a fully autonomous charging station that harnesses solar energy through high-efficiency photovoltaic panels, converting sunlight into electrical power stored in its integrated battery system.

Completely off-grid, it requires no external energy supply, making it ideal for charging bicycles, e-scooters, and other micromobility devices in any location.

For enhanced user experience and remote management, the BICICHARGER Solar can be paired with your smartphone or device via the **VictronConnect** App (optional), allowing for real-time monitoring and control.

Safety and energy management are key:

Equipped with a **pre-configured 1-hour current limiter** to optimize usage and prevent overcharging

Includes an **automatic earth fault detection and reset system** for safe operation

The certified **Safety Plus power sockets** feature shuttered, protected contacts, **with IK10 impact resistance and IP55 weatherproof** rating, ensuring durability in exposed public spaces such as parks, sports venues, and transport hubs.

BICICHARGER solar

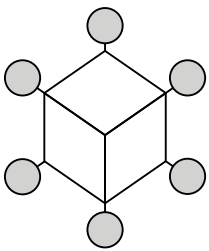

OPTIONAL BLUETOOTH CONNECTIVITY VICTRONCONNECT COMPATIBLE:

MONITOR REAL-TIME DATA ON YOUR MOBILE DEVICE, INCLUDING:

- Solar panel power generation
- Battery status
- Energy consumption

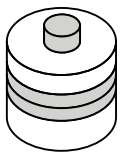

POWER SYSTEM

SOLAR PANEL	CHARGING TIME	POWER OUTPUT PER SOCKET
1 × 130W Monocrystalline Photovoltaic Panel	Default setup limited to 1 hour per session (via start switch)	Up to 600W

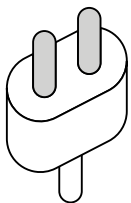

CHARGING INTERFACES

AC OUTLETS	USB PORTS
2 × Schuko 230V Sockets	2 × USB-A + 2 × USB-C Ports

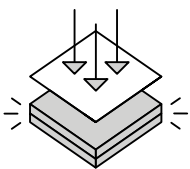

DURABILITY

SOCKET SPECIFICATIONS
K10 Impact Resistance / P55 Weatherproof Rating



SAFETY

ELECTRICAL EARTH FAULT PROTECTION	USAGE LIMITER	CHILD PROOF
Automatic detection and reset system	Pre-configured current limitation for controlled energy consumption	Shuttered & Childproof (Protected Contact Holes)

BICICHARGER solar

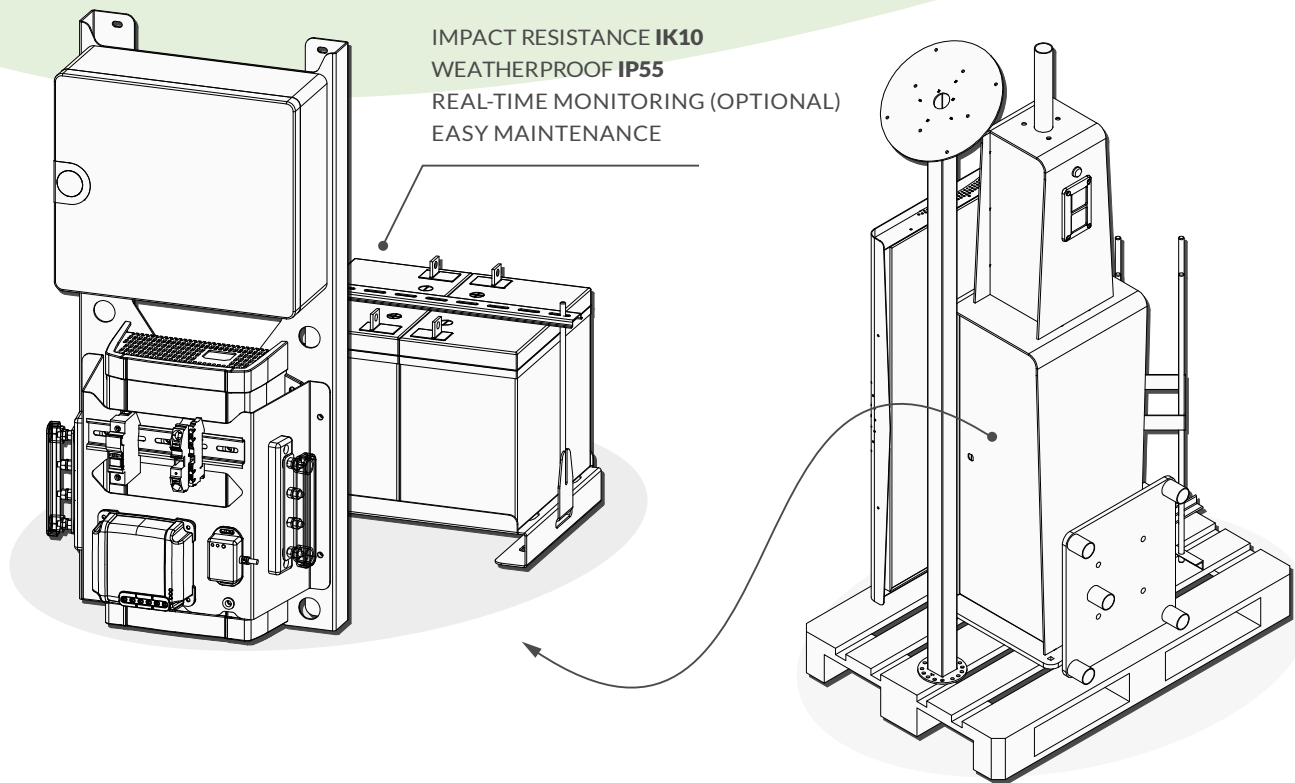

IMPACT RESISTANCE **IK10**
 WEATHERPROOF **IP55**
 REAL-TIME MONITORING (OPTIONAL)
 EASY MAINTENANCE

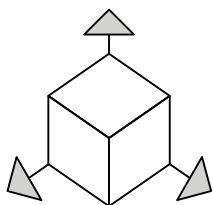

FEATURES

DIMENSIONS	WEIGHT	COLORS	INSTALLATION
1070x732x4060mm	130Kg	Several RAL colors	In - ground fundation Cast - in fixing kit Fundation cage supplied

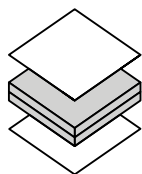

PRODUCTION

MATERIAL	PROTECTION	COATING
Carbon steel	Zinc thermal spray galvanizing	Electrostatic powder coating

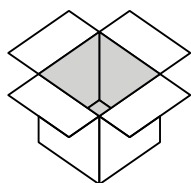

ORDERS

REFERENCE	SHIPPING DIMENSIONS	SHIPPING WEIGHT
BCW.ME001	1200x800x2200mm EUR - Pallet	150Kg